

METAL EXPANSION JOINT

Floor to Floor | Floor to Wall
25 - 150 mm (1 - 6") Expansion Gaps

Megatec 300 : A01-A02

Megatec 300 : A01

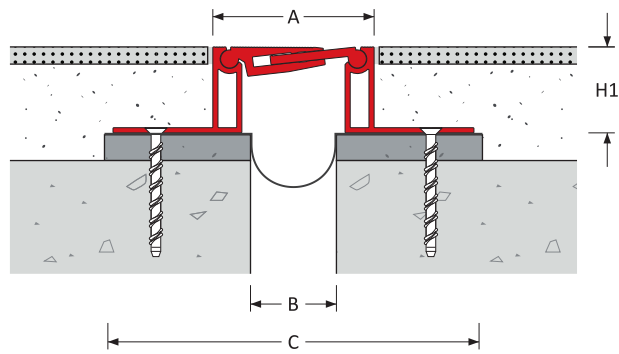

Megatec 300 : A02

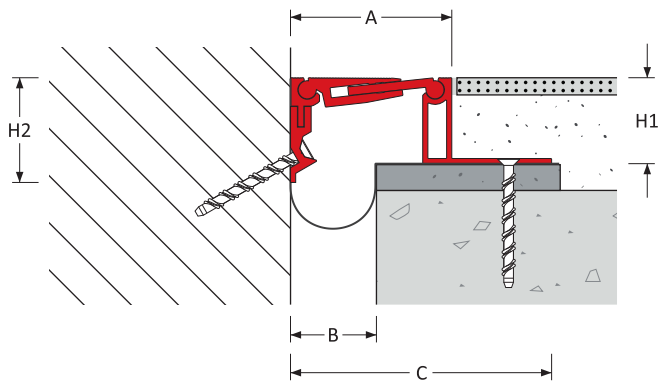

Expansion Joint Selection Criteria

Load Rating

Product Details

Joint Location	Gap Width B (mm)	Movement Capacity (mm)		Eurocode Rating				Product Dimensions		Sightline A (mm)	Blockout C (mm)	Product Number
		±	[Total]					H1 (mm)	H2 (mm)			
Floor – Floor	25	± 5	[10]	10 kN	69 kN	30 kN	300 kN	25: 35: 50: 75	-	69	185	300-A01-025-(H1)
	50	± 10	[20]							94	210	300-A01-050-(H1)
	75	± 15	[30]							119	235	300-A01-075-(H1)
	100	± 20	[40]							144	260	300-A01-100-(H1)
	125	± 30	[60]							169	285	300-A01-125-(H1)
	150	± 40	[80]							194	310	300-A01-150-(H1)
Floor – Wall	25	± 5	[10]	10 kN	69 kN	30 kN	300 kN	25: 35: 50: 75	61	69	127	300-A02-025-(H1)
	50	± 10	[20]							94	152	300-A02-050-(H1)
	75	± 15	[30]							119	177	300-A02-075-(H1)
	100	± 20	[40]							144	202	300-A02-100-(H1)
	125	± 30	[60]							169	227	300-A02-125-(H1)
	150	± 40	[80]							194	252	300-A02-150-(H1)

When specifying or ordering please add the **height (H1)** required to the Product Reference.
For example Megatec 300 : A01-075-050 denotes a joint 50mm high.

Features

Surface

Smooth transit

Hairline serrated surface for improved slip resistance

Americans with Disabilities Act (ADA) compliant across the entire movement cycle

Movement

High movement capacity

ASTM E-1399 Class I: Thermal

Class II: Wind

Traffic Frequency per day

				
> 25,000	≤ 1,000	≤ 1,000	≤ 1,000	≤ 10

System Options

Gap width(s)	25, 50, 75, 100, 125, 150 mm
Height(s)	25, 35, 50, 75 mm
Metal type(s)	Aluminium
Seal colour(s)	No seal used
Fire barrier	120-240 minutes
Waterproofing	Moisture barrier
Pre-assembly in factory	Contact Vexcolt Europe



Megatec 300 : A01-A02



APPLICATIONS

Airport Terminals | Educational | Exhibition Centres
 Department Stores | Distribution & Retail Warehouses
 Factories | Hospitals | Museums | Offices & Hotels
 Parking | Places of Worship | Residential Buildings
 Rail, Metros & Elevated Rail Stations | Roads & Bridges
 Shopping Centres | Sports Stadiums | Supermarkets