

SEAL EXPANSION JOINT

Concrete to Concrete | Steel to Steel

50 - 250 mm (2 - 10") Expansion Gaps

Omegatec 1300 : A01

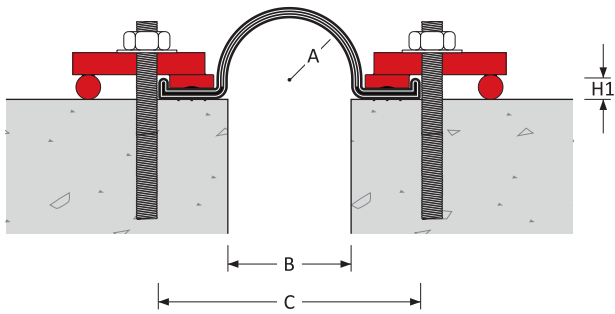

Expansion Joint Selection Criteria

Load Rating

Product Details

Joint Location	Gap Width B (mm)	Movement Capacity (mm)		Water Pressure		Product Dimensions				
		±	[Total]	Seal Fully Open Mpa	Seal Fully Closed Mpa	Height H1 (mm)	Stud Fixing (mm)	Radius A (mm)	Width C (mm)	Product Number
Concrete- Concrete Steel - Steel	50	+40/-30	[70]	0.75	1.75	13	M24	25	210	1300-A01-050
	80	+60/-40	[100]					40	240	1300-A01-080
	100	+70/-50	[120]	0.50	1.20			50	260	1300-A01-100
	140	± 70	[140]					70	300	1300-A01-140
	200	± 90	[180]	0.30	0.80		M30	100	360	1300-A01-200
	250	± 100	[200]	0.25	0.75			18	120	410

Features

Surface

Omega-type seal

Movement

High movement capacity

ASTM E-1399 Class I: Thermal
Class II: Wind
Class III: Seismic

Traffic Frequency per day



- - - - -

System Options

Gap width(s)	50, 80, 100, 140, 200, 250 mm
Height(s)	13, 18 mm
Metal type(s)	Galvanised Steel clamping system
Colour(s)	Black
Fire barrier	120-240 minutes
Waterproofing	Max. water pressure 1.75 MPa
Pre-assembly in factory	Contact Vexcolt Europe

Omegatec 1300 : A01

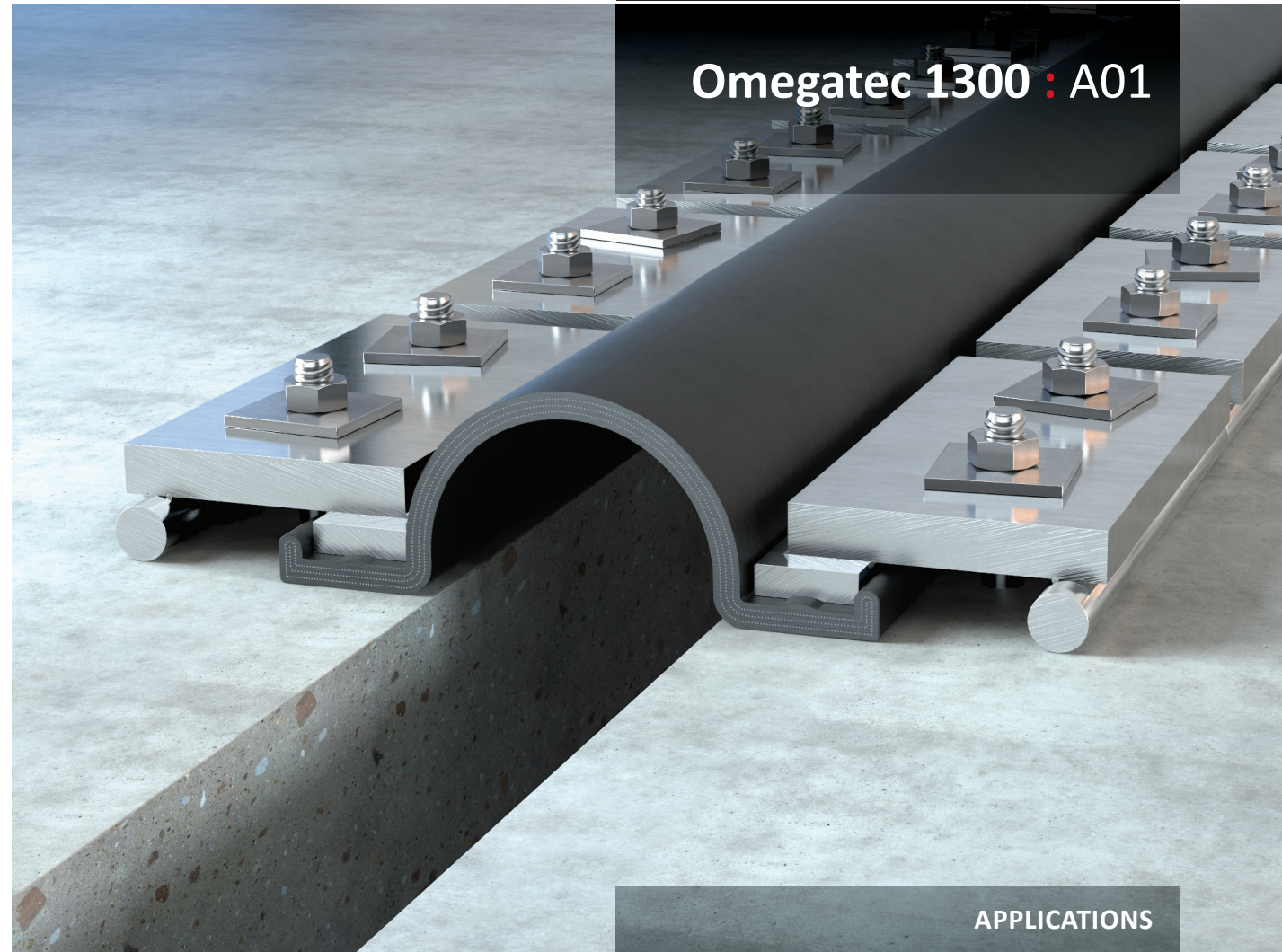

APPLICATIONS

- Immersed Tunnels
- Bored Tunnels
- Aqueducts
- Roads & Bridges
- Submersed Structures

SEAL EXPANSION JOINT

Concrete to Concrete | Steel to Steel

50 - 250 mm (2 - 10") Expansion Gaps

Omegatec 1300 : A01

Water Pressure Capacity vs Seal Movement Range

All **Omegatec 1300 : A01** seals are formed with three layers of nylon reinforcement as standard.

The minimum water pressure Factor of Safety is 3.0.

Omegatec 1300 : A01-050

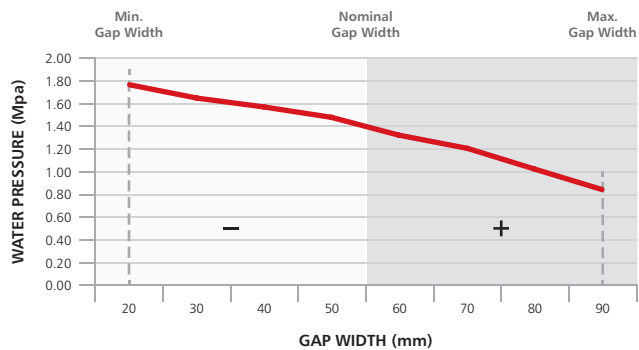

Omegatec 1300 : A01-080

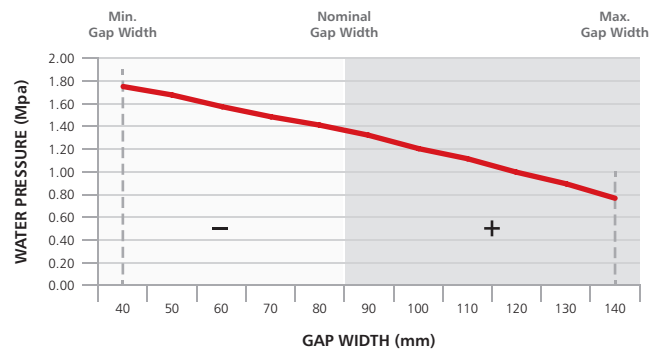

Omegatec 1300 : A01-100

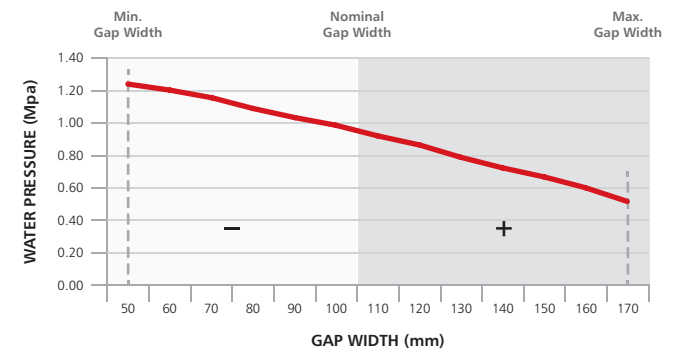

Omegatec 1300 : A01

Omegatec 1300 : A01-140

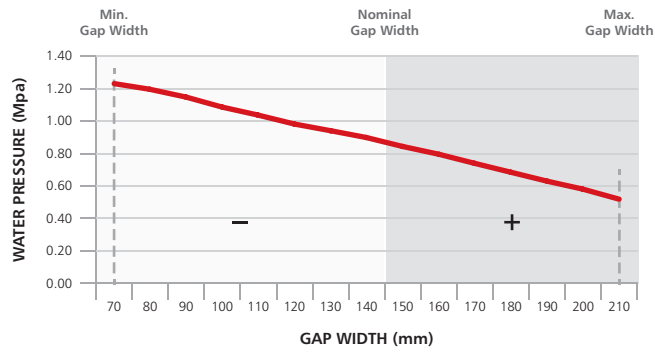

Omegatec 1300 : A01-200

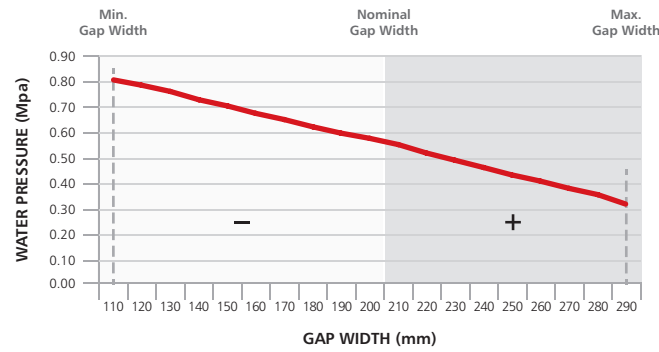

Omegatec 1300 : A01-250

