

## SEISMIC EXPANSION JOINT

Floor to Floor | Floor to Wall

50 - 500 mm ( 2 - 20" ) Expansion Gaps

# Seismatec 430 : A01-A02

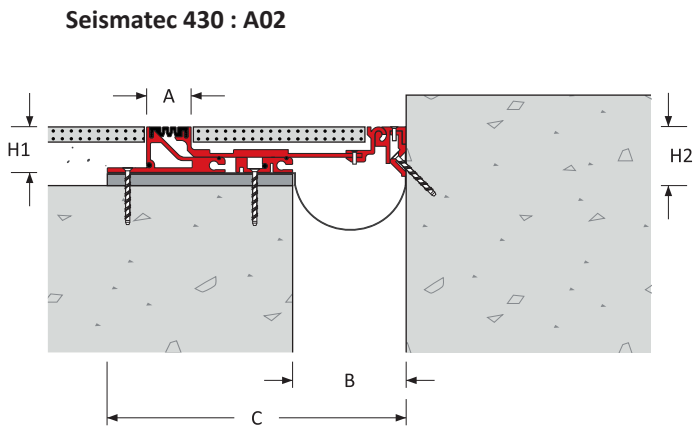
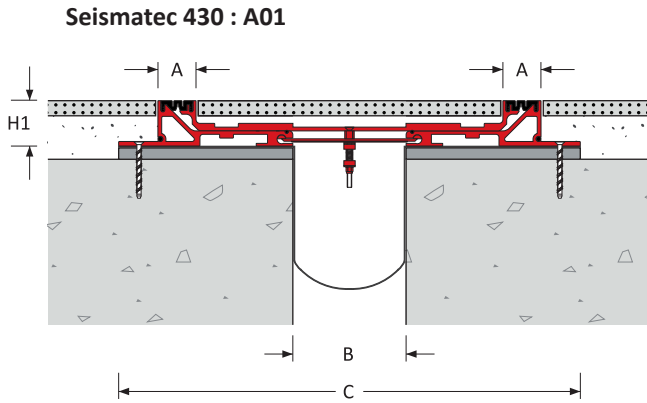

### Expansion Joint Selection Criteria

### Load Rating

### Product Details

Joint Location	Gap Width B (mm)	Movement Capacity (mm)		Eurocode Rating				Product Dimensions			Product Number		
		Thermal ±	[Total]	Seismic ±	[Total]					Height H1 (mm)		H2 (mm)	Sightline A (mm)
Floor - Floor	50	± 12.5	[25]	±25.0	[50]	20 kN	69 kN	30 kN	50:60	-	51	511	430-A01-050-(H1)
	75			±37.5	[75]							536	430-A01-075-(H1)
	100			±50.0	[100]							561	430-A01-100-(H1)
	150			±75.0	[150]							611	430-A01-150-(H1)
	200			±100	[200]	10 kN	46 kN					661	430-A01-200-(H1)
	250			±125	[250]	715	430-A01-250-(H1)						
	300			±150	[300]	928	430-A01-300-(H1)						
	400			±200	[400]	1028	430-A01-400-(H1)						
500	±250	[500]	5 kN	36 kN	1128	430-A01-500-(H1)							
Floor - Wall	50	± 12.5	[25]	±25.0	[50]	20 kN	69 kN	30 kN	50:60	74	59	323	430-A02-050-(H1)
	75			±37.5	[75]							336	430-A02-075-(H1)
	100			±50.0	[100]							348	430-A02-100-(H1)
	150			±75.0	[150]							395	430-A02-150-(H1)
	200			±100	[200]	470	430-A02-200-(H1)						
	250			±125	[250]	556	430-A02-250-(H1)						
	300			±150	[300]	645	430-A02-300-(H1)						
	400			±200	[400]	795	430-A02-400-(H1)						
500	±250	[500]	5 kN	36 kN	956	430-A02-500-(H1)							

- a. 50mm deep systems are only suitable for the installation of 10mm deep paving within the central pan
- b. 60mm deep systems are suitable for the installation of paving up to 20mm deep within the central pan

## Features

### Surface

Smooth transit central pan system

### Movement

Seismic movement capacity

ASTM E-1399 Class I: Thermal

Class II: Wind

Class III: Seismic

Thermal & Wind movement: +/-12.5mm

Seismic movement: +/-50% of expansion gap width

## Traffic Frequency per day

				
> 25,000	≤ 1,000	≤ 1,000	≤ 100	-

## System Options

Gap width(s)	50, 75, 100, 150, 200, 250, 300, 400, 500 mm
Height(s)	50, 60 mm
Metal type(s)	Aluminium
Seal colour(s)	Black, Grey, Stone
Fire barrier	120-240 minutes
Waterproofing	Waterproofing membrane
Pre-assembly in factory	Contact Vexcolt Europe

## Seismatec 430 : A01-A02



## APPLICATIONS

Airport Terminals | Educational | Exhibition Centres  
 Department Stores | Distribution & Retail Warehouses  
 Factories | Hospitals | Museums | Offices & Hotels  
 Parking | Places of Worship | Residential Buildings  
 Rail, Metros & Elevated Rail Stations | Roads & Bridges  
 Shopping Centres | Sports Stadiums | Supermarkets