

METAL EXPANSION JOINT

Floor to Floor | Floor to Wall
25 - 50 mm (1 - 2") Expansion Gaps

Megatec 360 : A01-A02

Megatec 360 : A01

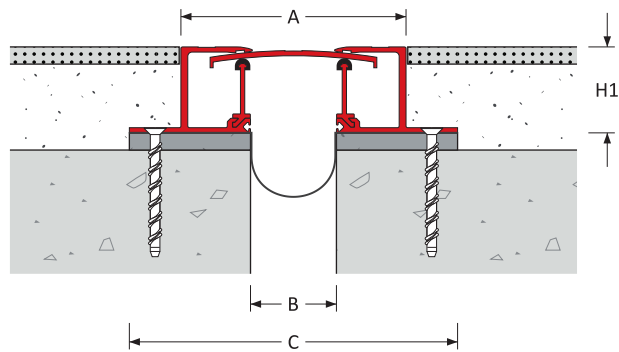

Megatec 360 : A02

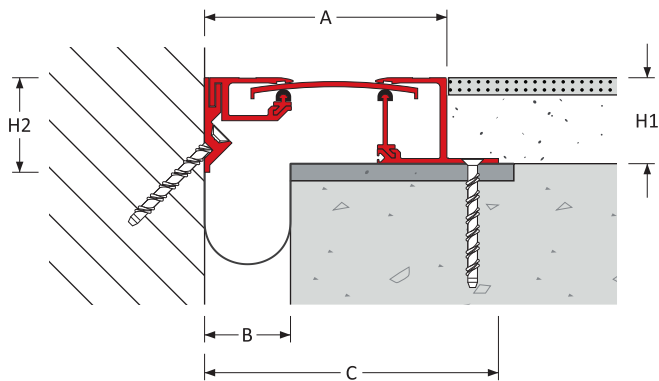

Expansion Joint Selection Criteria

Load Rating

Product Details

Joint Location	Gap Width B (mm)	Movement Capacity (mm)		Eurocode Rating				Product Dimensions				Product Number
		±	[Total]					Height		Sightline	Blockout	
								H1 (mm)	H2 (mm)	A (mm)	C (mm)	
Floor – Floor	25	± 12	[25]	2 kN	31 kN	-	-	25: 38: 50	-	81	141	360-A01-025-(H1)
	50	± 25	[50]	-	-	-	-			131	191	360-A01-050-(H1)
Floor – Wall	25	± 12	[25]	2 kN	31 kN	-	-	25: 38: 50	55	91	121	360-A02-025-(H1)
	50	± 25	[50]	-	-	-	-			141	171	360-A02-050-(H1)

When specifying or ordering please add the height (H1) required to the Product Reference.
For example 360-A01-025-050 denotes a joint 50mm high.

Features

Surface

Smooth transit
Americans with Disabilities Act (ADA) compliant
across the entire movement cycle

Movement

Good movement capacity
ASTM E-1399 Class I: Thermal
Class II: Wind

Traffic Frequency per day

				
≤ 5,000	≤ 10	-	-	-

System Options

Gap width(s)	25, 50 mm
Height(s)	25, 38, 50 mm
Metal type(s)	Aluminium
Seal colour(s)	No seal used
Fire barrier	120-240 minutes
Waterproofing	Moisture barrier
Pre-assembly in factory	Contact Vexcolt Europe



Megatec 360 : A01-A02



APPLICATIONS

Airport Terminals | Educational | Exhibition Centres
Department Stores | Distribution & Retail Warehouses
Factories | Hospitals | Museums | Offices & Hotels
Parking | Places of Worship | Residential Buildings
Rail, Metros & Elevated Rail Stations | Roads & Bridges
Shopping Centres | Sports Stadiums | Supermarkets