

## METAL EXPANSION JOINT

Floor to Floor | Floor to Wall

25 - 300 mm ( 1 - 12" ) Expansion Gaps

# Megatec 340 : A01-A02

Megatec 340 : A01

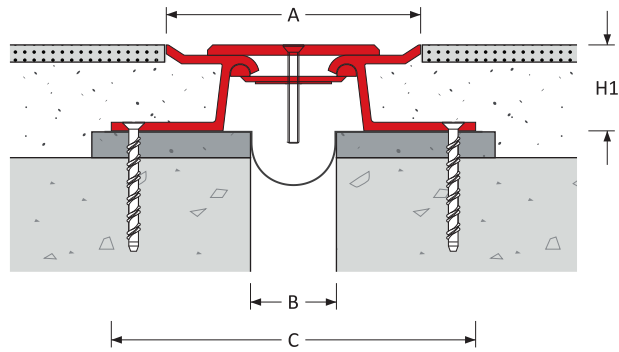

Megatec 340 : A02

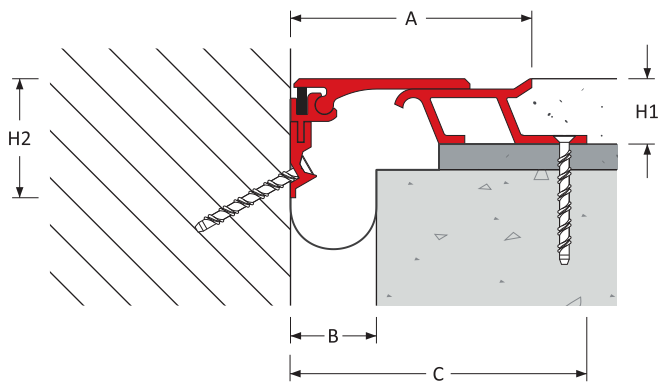

### Expansion Joint Selection Criteria

### Load Rating

### Product Details

Joint Location	Gap Width B (mm)	Movement Capacity (mm)		Eurocode Rating				Product Dimensions			Product Number	
		±	[Total]					Height		Sightline		Blockout
								H1 (mm)	H2 (mm)	A (mm)	C (mm)	
Floor – Floor	25	± 12	[25]	10 kN	150 kN	30 kN	-	25: 38: 50	-	126	190	340-A01-025-(H1)
	50	± 25	[50]	5 kN	46 kN					139	203	340-A01-050-(H1)
	75	± 37	[75]	2 kN	31 kN					187	242	340-A01-075-(H1)
	100	± 50	[100]	-	-	216				280	340-A01-100-(H1)	
	150	± 75	[150]	-	-	308				372	340-A01-150-(H1)	
	200	± 100	[200]	-	-	408				472	340-A01-200-(H1)	
	250	± 125	[250]	-	-	522				586	340-A01-250-(H1)	
	300	± 150	[300]	-	-	622				686	340-A01-300-(H1)	
Floor – Wall	25	± 12	[25]	10 kN	150 kN	30 kN	-	25: 38: 50	70	118	150	340-A02-025-(H1)
	50	± 25	[50]	5 kN	46 kN					141	173	340-A02-050-(H1)
	75	± 37	[75]	2 kN	31 kN					188	220	340-A02-075-(H1)
	100	± 50	[100]	-	-	226				258	340-A02-100-(H1)	
	150	± 75	[150]	-	-	298				330	340-A02-150-(H1)	
	200	± 100	[200]	-	-	373				405	340-A02-200-(H1)	
	250	± 125	[250]	-	-	448				480	340-A02-250-(H1)	
	300	± 150	[300]	-	-	523				555	340-A02-300-(H1)	

When specifying or ordering please add the **height (H1)** required to the Product Reference.  
For example Megatec 340 : A01-075-050 denotes a joint 50mm high.

## Features

### Surface

Hairline serrated surface for improved slip resistance  
Americans with Disabilities Act (ADA) compliant  
across the entire movement cycle

### Movement

Seismic movement capacity  
ASTM E-1399 Class I: Thermal  
Class II: Wind  
Class III: Seismic

## Traffic Frequency per day

				
> 25,000	≤ 1,000	≤ 100	≤ 100	-

## System Options

Gap width(s)	25, 50, 75, 100, 150, 200, 250, 300 mm
Height(s)	25, 38, 50 mm
Metal type(s)	Aluminium
Seal colour(s)	No seal used
Fire barrier	120-240 minutes
Waterproofing	Moisture barrier
Pre-assembly in factory	Contact Vexcolt Europe

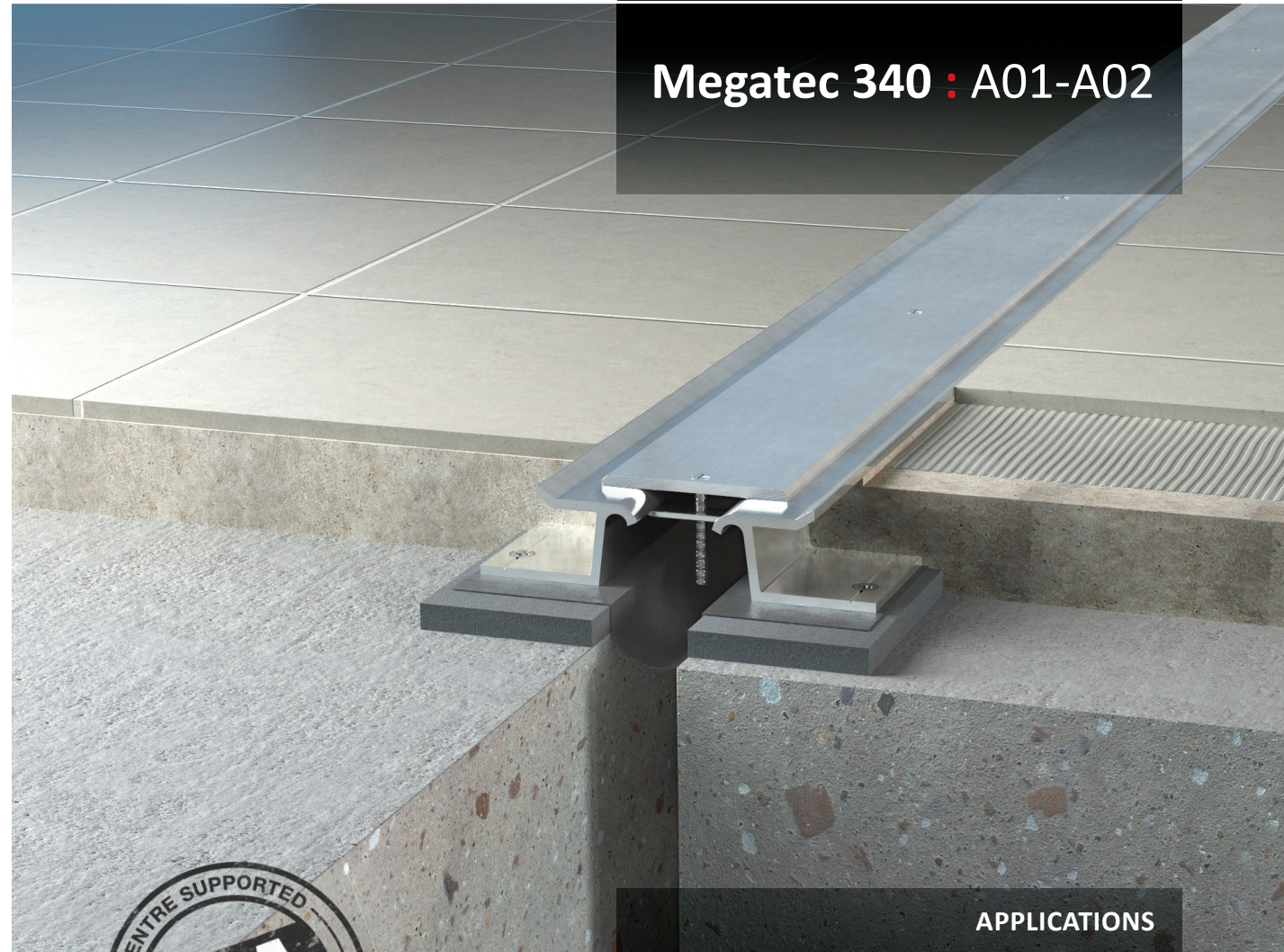

# Megatec 340 : A01-A02



## APPLICATIONS

Airport Terminals | Educational | Exhibition Centres  
Department Stores | Distribution & Retail Warehouses  
Factories | Hospitals | Museums | Offices & Hotels  
Parking | Places of Worship | Residential Buildings  
Rail, Metros & Elevated Rail Stations | Roads & Bridges  
Shopping Centres | Sports Stadiums | Supermarkets