

METAL EXPANSION JOINT

Floor to Floor

25 - 50 mm (1 - 5") Expansion Gaps

Megatec 330 : S01-S02

Megatec 330 : S01

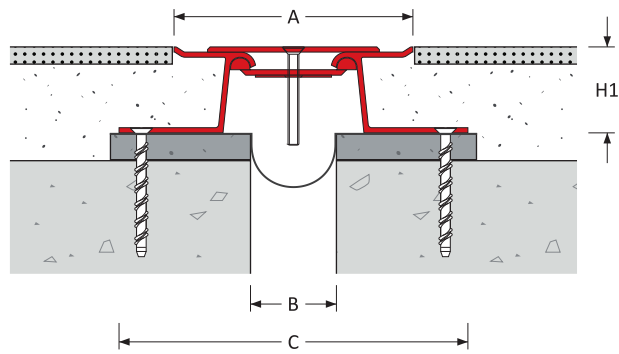

Megatec 330 : S02

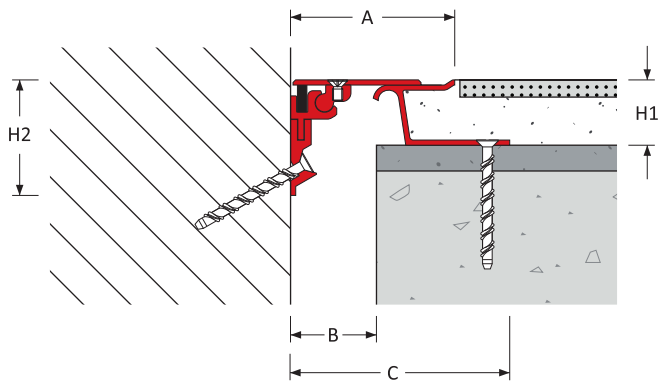

Expansion Joint Selection Criteria

Load Rating

Product Details

Joint Location	Gap Width B (mm)	Movement Capacity (mm)		Eurocode Rating				Product Dimensions				Product Number
		±	[Total]					Height		Sightline	Blockout	
								H1 (mm)	H2 (mm)	A (mm)	C (mm)	
Floor – Floor	25	± 12	[25]	2 kN	31 kN	–	–	25: 38: 50	–	127	191	330–S01–025–(H1)
	50	± 25	[50]	–	–	–	–			139	203	330–S01–050–(H1)
Floor – Wall	25	± 6	[12]	–	–	–	–	25: 28: 50	67	90	122	330–S02–025–(H1)
	50	± 12	[25]	–	–	–	–			96	128	330–S02–050–(H1)

When specifying or ordering please add the **height (H1)** required to the Product Reference.
For example Megatec 330 : S01-050-038 denotes a joint 38mm high.

Features

Surface

80-grit surface finish to stainless steel for improved slip resistance
Americans with Disabilities Act (ADA) compliant
across the entire movement cycle

Movement

High movement capacity
ASTM E-1399 Class I: Thermal
Class II: Wind

Traffic Frequency per day

				
≤ 10,000	≤ 100	≤ 10	-	-

System Options

Gap width(s)	25, 50 mm
Height(s)	25, 38, 50 mm
Metal type(s)	Aluminium
	Stainless Steel Top Plate
Seal colour(s)	No seal used
Fire barrier	120-240 minutes
Waterproofing	Moisture barrier
Pre-assembly in factory	Contact Vexcolt Europe

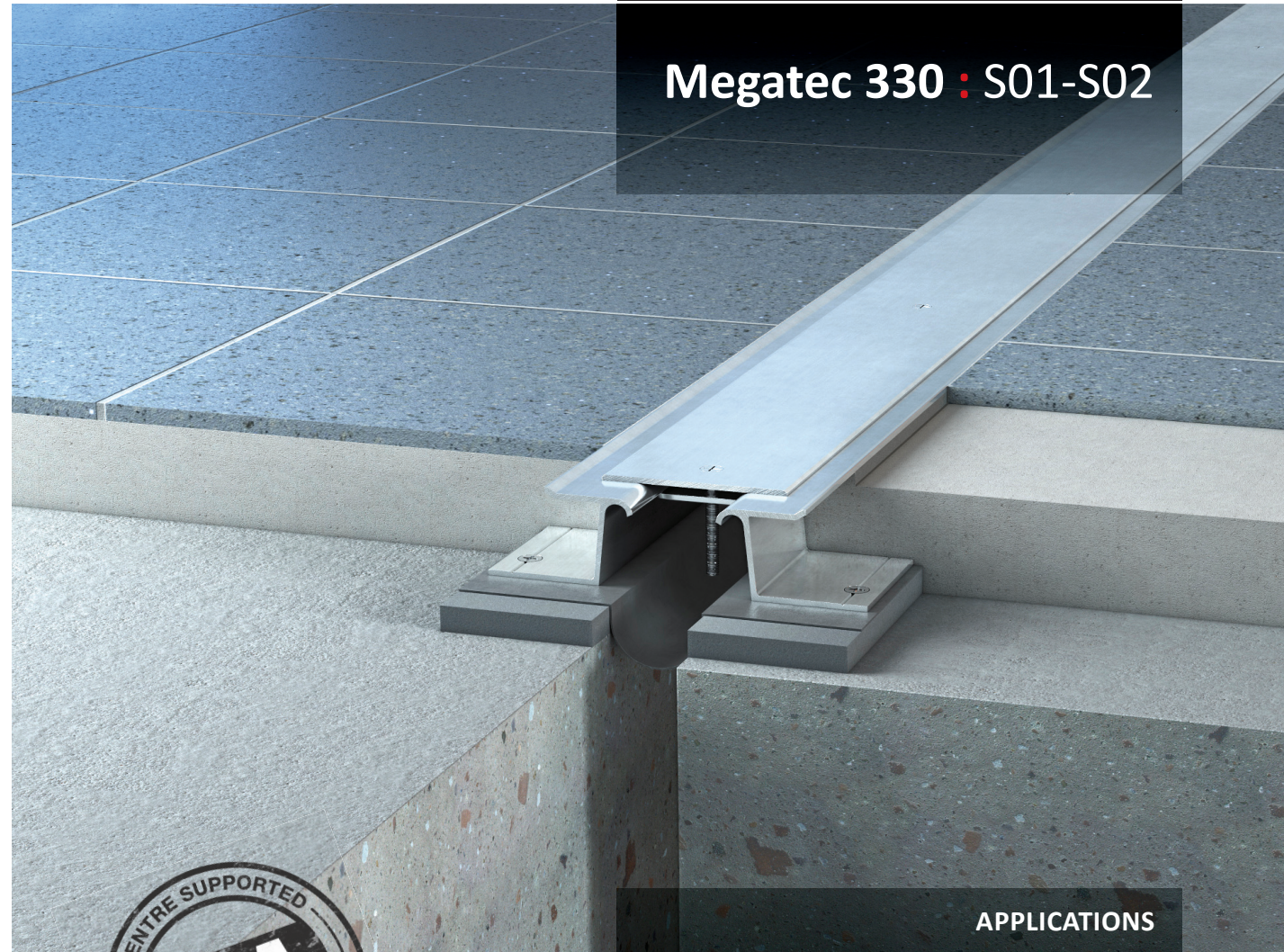

Megatec 330 : S01-S02



APPLICATIONS

Airport Terminals | Educational | Exhibition Centres
Department Stores | Distribution & Retail Warehouses
Factories | Hospitals | Museums | Offices & Hotels
Parking | Places of Worship | Residential Buildings
Rail, Metros & Elevated Rail Stations | Roads & Bridges
Shopping Centres | Sports Stadiums | Supermarkets