

FIRE BARRIER SYSTEM

Floor to Floor | Wall to Wall | Corner
25 - 500 mm (1 - 20") Expansion Gaps

FireFlex 2100 : A01-A02

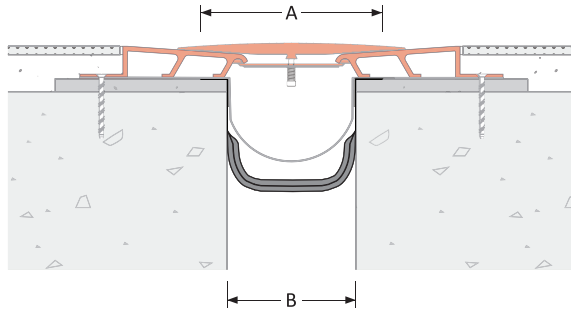

Fire Barrier Selection Criteria

Load Rating

Product Details

Joint Location	Gap Width B (mm)	Movement Capacity (mm)		Eurocode Rating				Product Dimensions		Sightline A (mm)	Blockout C (mm)	Product Number
		±	[Total]					H1 (mm)	H2 (mm)			
2 Hour Fire Rated (120 mins)												
Floor – Floor Wall – Wall Ceiling – Ceiling	25	± 12	[25]							95		2100-A01-025-2
	50	± 25	[50]							120		2100-A01-050-2
	75	± 37	[75]							145		2100-A01-075-2
	100	± 50	[100]							170		2100-A01-100-2
	125	± 62	[125]							195		2100-A01-125-2
	150	± 75	[150]							220		2100-A01-150-2
	200	± 100	[200]	-	-	-	-	-	-	270	-	2100-A01-200-2
	250	± 125	[250]							320		2100-A01-250-2
	300	± 150	[300]							370		2100-A01-300-2
	350	± 175	[350]							420		2100-A01-350-2
	400	± 200	[400]							470		2100-A01-400-2
	450	± 225	[450]							520		2100-A01-450-2
	500	± 250	[500]							570		2100-A01-500-2
2 Hour Fire Rated (120 mins)												
Floor – Wall Corner Wall Wall – Ceiling	25	± 12	[25]							60		2100-A02-025-2
	50	± 25	[50]							85		2100-A02-050-2
	75	± 37	[75]							110		2100-A02-075-2
	100	± 50	[100]							135		2100-A02-100-2
	125	± 62	[125]							160		2100-A02-125-2
	150	± 75	[150]							185		2100-A02-150-2
	200	± 100	[200]	-	-	-	-	-	-	235	-	2100-A02-200-2
	250	± 125	[250]							285		2100-A02-250-2
	300	± 150	[300]							335		2100-A02-300-2
	350	± 175	[350]							385		2100-A02-350-2
	400	± 200	[400]							435		2100-A02-400-2
	450	± 225	[450]							485		2100-A02-450-2
	500	± 250	[500]							535		2100-A02-500-2

Features

Movement

Seismic movement capacity

ASTM E-1399 Class I: Thermal
Class II: Wind
Class III: Seismic

Material

High-temperature refractory ceramic fibre
Stainless steel foil sheath

Traffic Frequency per day



- - - - -

System Options

Gap width(s)	25, 50, 75, 100, 125, 200, 250, 300, 350, 400, 450, 500 mm
Height(s)	Not applicable
Metal type(s):	Stainless Steel foil
Colour(s)	Stainless Steel finish
Fire barrier	UL 2079: 120 minutes
Waterproofing	Waterproofing membrane
Pre-assembly in factory	Contact Vexcolt Europe

FireFlex 2100 : A01-A02

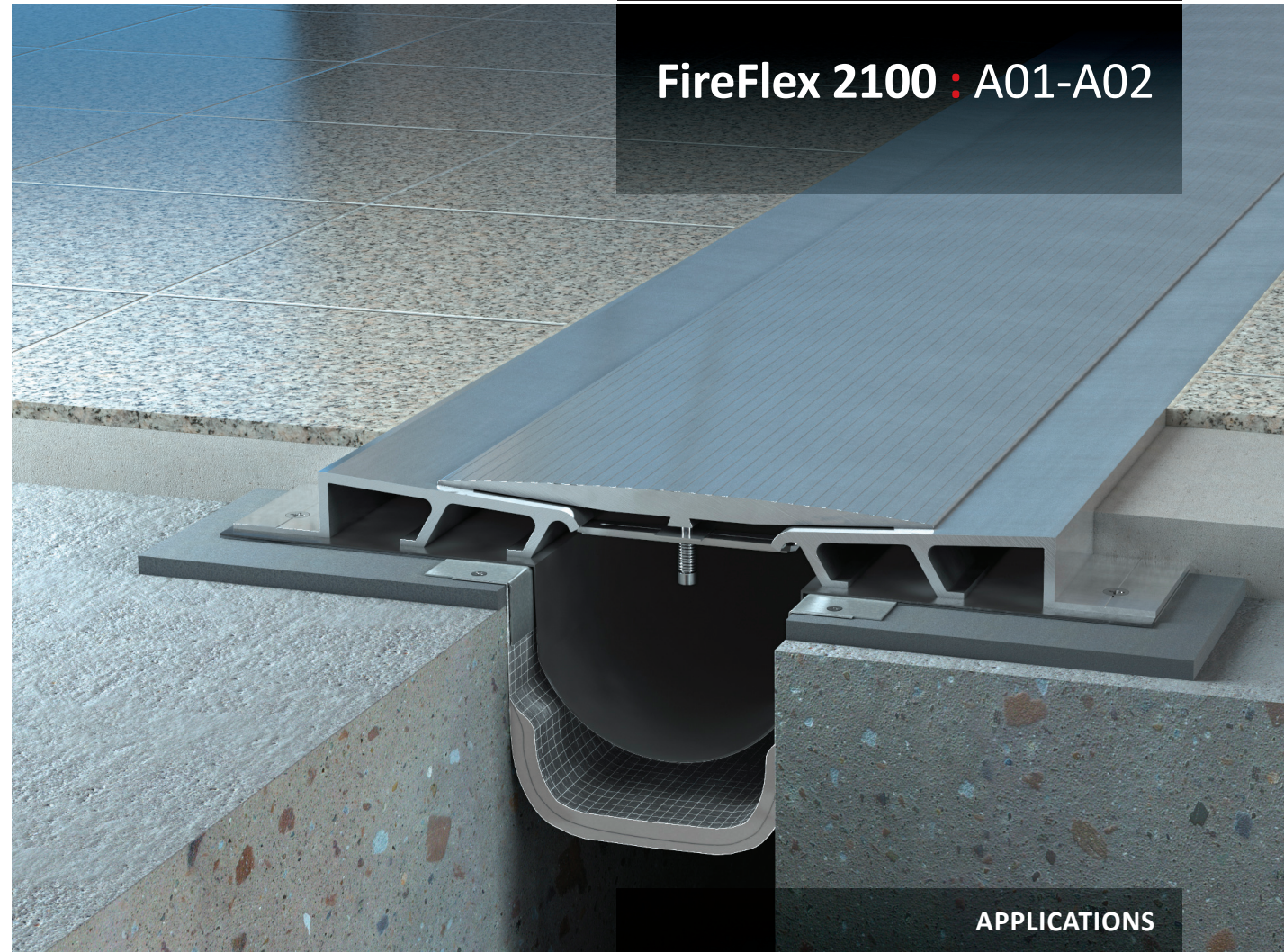

APPLICATIONS

Airport Terminals | Educational | Exhibition Centres
Department Stores | Distribution & Retail Warehouses
Factories | Hospitals | Museums | Offices & Hotels
Parking | Places of Worship | Residential Buildings
Rail, Metros & Elevated Rail Stations | Roads & Bridges
Shopping Centres | Sports Stadiums | Supermarkets